

Hurricane **Series**

*Innovation in Pursuit
of Perfection*

HS-2



HS



HS-1



UNIPRESS



Innovation in Pursuit of Perfection

The Hurricane Series has it all - Easy to Use - Advanced Technology
Steadfast Reliability and Most Importantly High-End Quality

HMI Touch Screen Display

The Hurricane Series features a Human Machine Interface (HMI) Touch Screen Display that works with a Programmable Logic Controller (PLC) to control the machine functions. Seamless integration of the HMI display, PLC, and supporting software makes the Hurricane easy to use. Once the machine is turned on, the operator is prompted to log in, run a warm-up cycle and begin pressing shirts.

On the display screen, the shirt count, hourly production rate and target rate are always present, reminding the operator to keep on task. Unipress' software collects production and machine function data. When the unit is connected to a network the real-time data is available through a mobile app, PC or Mac. All of the data collected can be accessed by designated personnel and converted into various reports:

Detailed Production Reports • Maintenance Notes • Service Logs • Operator History



PVP - Pleat Vent Press

The Pleat Vent Press (PVP) has become synonymous with a superior quality finish. Pressing the pleated area of the sleeve to an optimum length of 2-3 inches from the cuff seam is a key benchmark.



Two Position Arms

A distinct Hurricane advantage is the adjustable arm height, making it easy to process tapered shirts with deep-cut sleeves. The Touch Screen Display has an "Arms Down" button that can be depressed while the operator is loading the shirt or when the shirt is in the pressing position. Regular- classic fit shirt sleeves are finished with the arms in the up position, which is the default position requiring no action by the operator. The arms are always in the down position while loading. This is five inches lower than previous models making the Hurricane easier and faster to load. Another benefit of the adjustable arms is at the end of the pressing cycle the cuff clamps release, the arms lower and fully extend away from the shirt, allowing the sleeves to drop down and out of the way before the arms retract for transfer.

Contoured Chests • Formed Bucks • Automatic Rear Tensioning Plate Side Air Bags • Rounded Cuff Clamps



The Hurricane Series incorporates Unipress' hallmark features - **Contoured Chests, Formed Bucks, Side Air Bags, Rounded Cuff Clamps** and **Automatic Rear Pull Down Tensioning Plate**. The combination of these features produces unsurpassed quality on shirts up to size 20". As the Contoured Chests begin to close, the Side Air Bags inflate; the back chest makes contact with Rear Tensioning Plate automatically pulling down the back of the shirt and presses the entire back and front of the shirt with no leave off marks.

**1 Operator up to
60 shirts per hour**

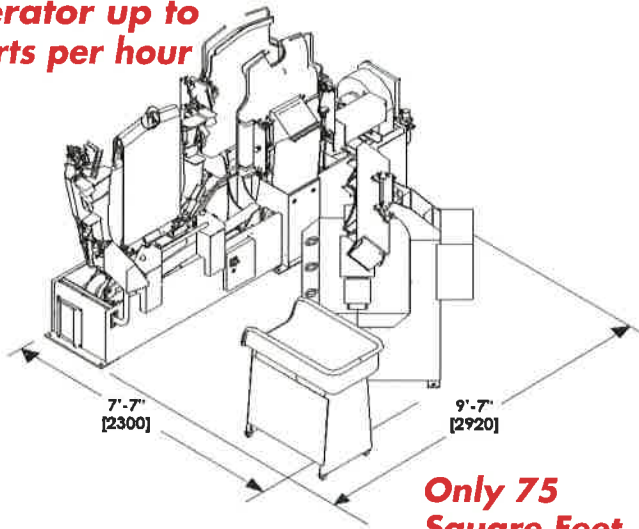

**Only 75
Square Feet**



HS

**1 Operator up to
60 shirts per hour**

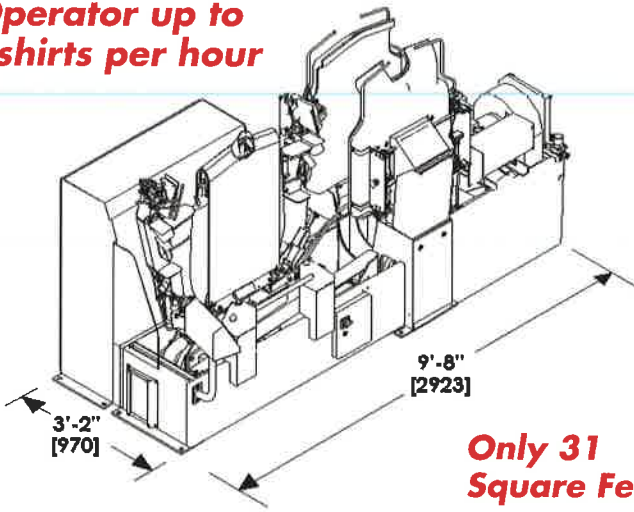

**Only 31
Square Feet**



HS-1

60 shirts per hour

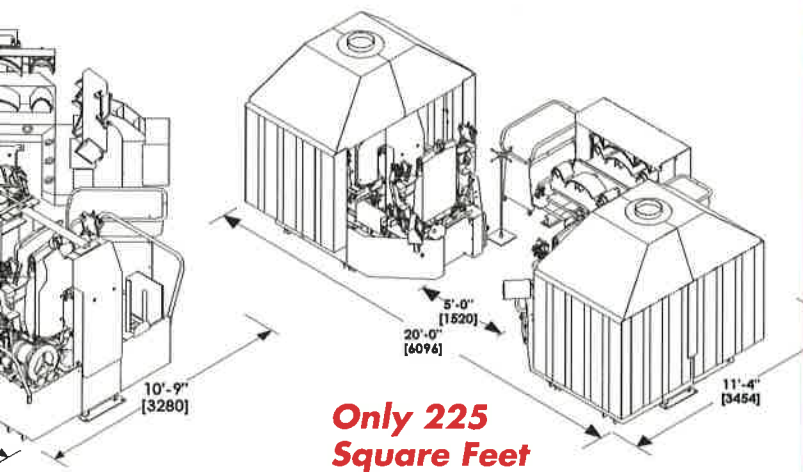

**Only 225
Square Feet**



HS-2H

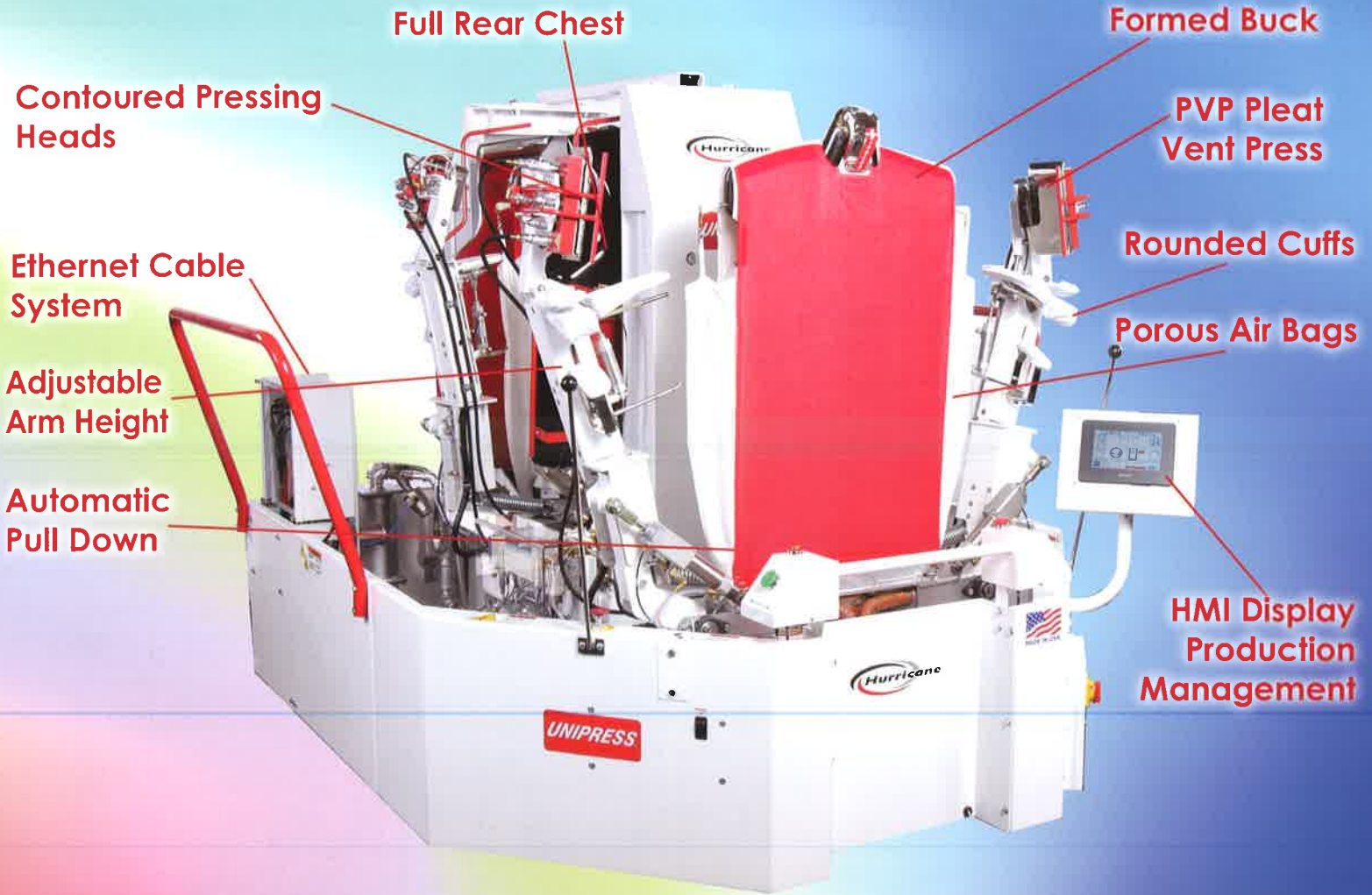

Hurricane

HS-2

**1 or 2 Operators,
60-100+ Shirts Per Hour**

3 Operators up to 200 + shirts Per Hour

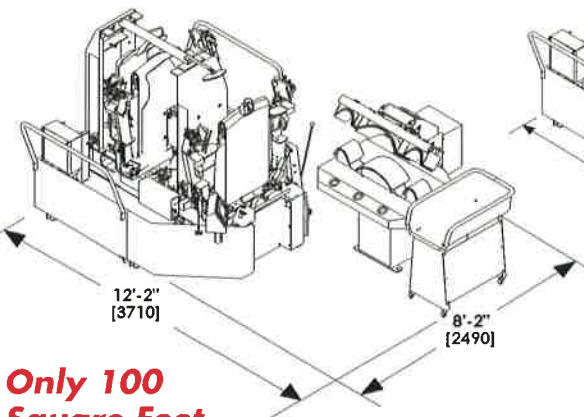

**Only 100
Square Feet**

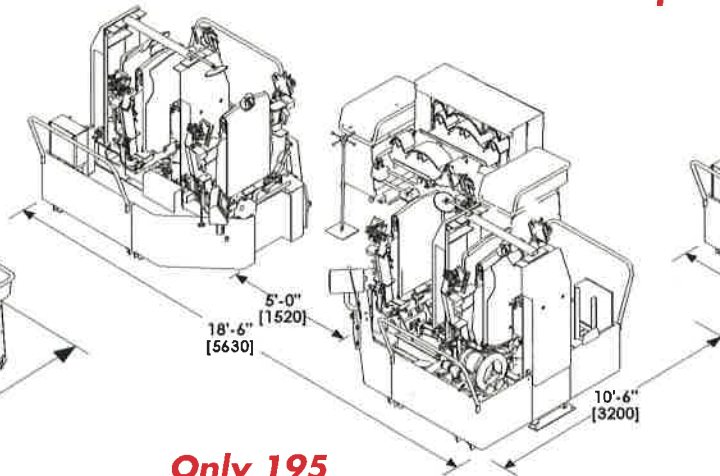

**Only 195
Square Feet**

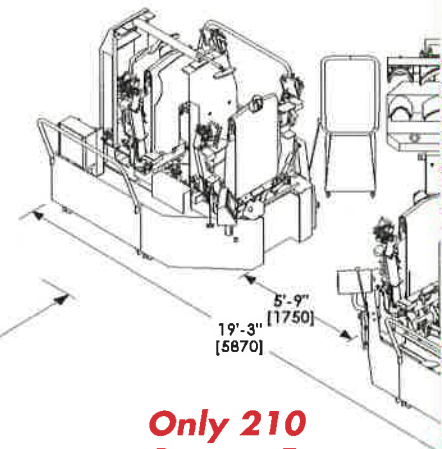

**Only 210
Square Feet**

Technical Data Hurricane

HS-2 Double Buck

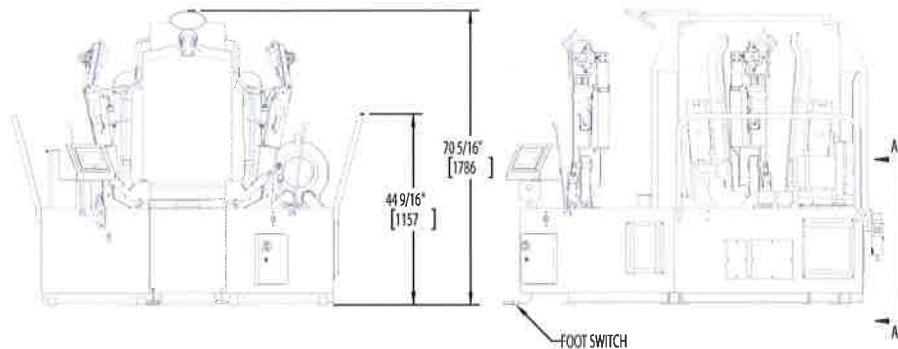
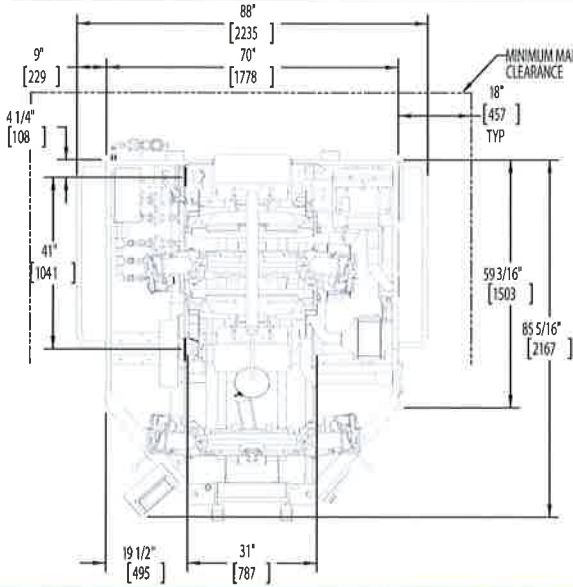

HS and HS-1 Single Bucks

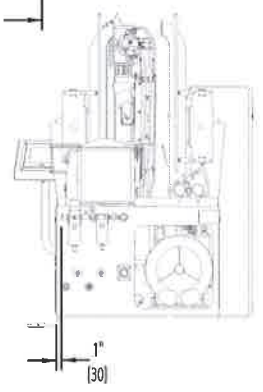
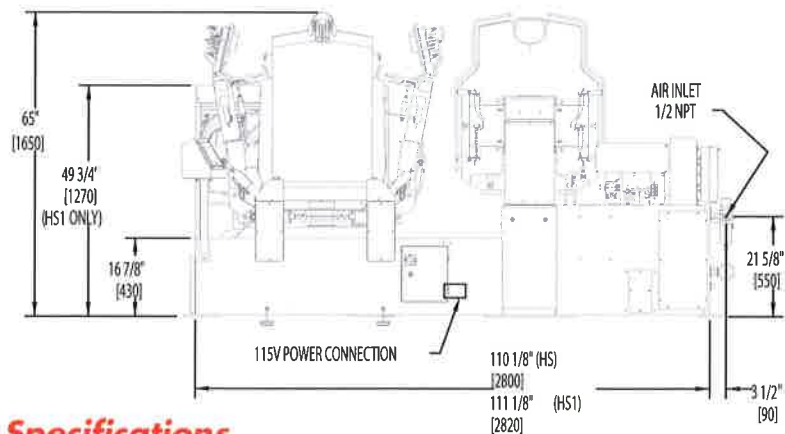
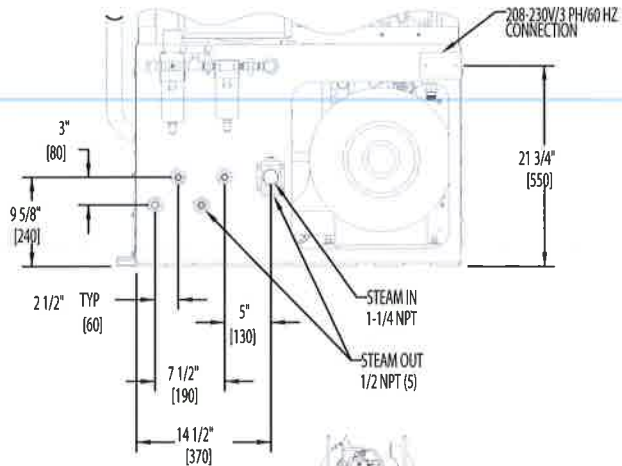
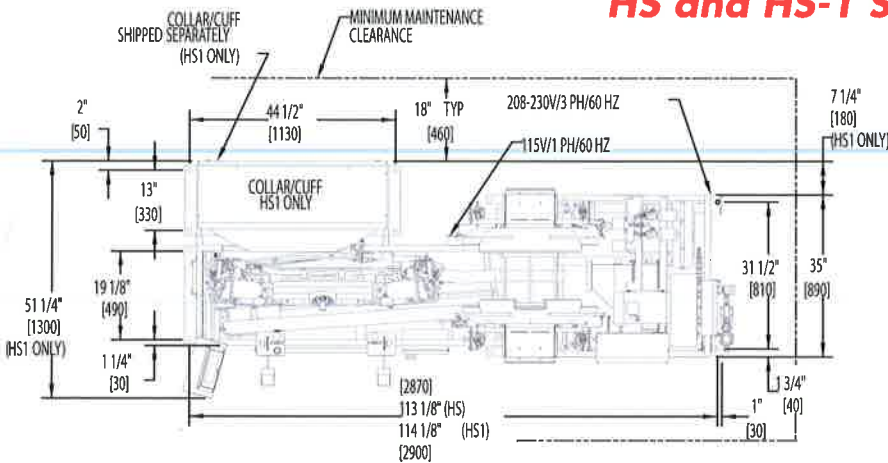

Specifications

	HS SAF	HS Metric	HS 1 SAF	HS 1 Metric	HS 2 SAF	HS 2 Metric
Overall Height	65"	1650 mm	65"	1650 mm	70.31"	1790 mm
Overall Length	115"	2920 mm	116"	2920 mm	85"	2172 mm
Overall Width	35"	890 mm	42 5/16"	1080 mm	88"	2235 mm
Steam Inlet	1-1/4" NPT	1-1/4" NPT	1-1/4" NPT	1-1/4" NPT	1-1/4" NPT	1-1/4" NPT
Steam Outlet	1/2" NPT (5)	1/2" NPT (5)	1/2" NPT (5)	1/2" NPT (5)	1/2" NPT (5)	1/2" NPT (5)
Steam Supply	100-125 psi	7-9 Bar	100-125 psi	7-9 Bar	100-125 psi	7-9 Bar
Boiler Horsepower	2.5 BHP	40 kg/hr	3.25 BHP	52 kg/hr	3.5 BHP	56 kg/hr
Air Inlet	1/2" NPT	1/2" NPT	1/2" NPT	1/2" NPT	1/2" NPT	1/2" NPT
Air Supply	85 PSI	6 Bar	85 PSI	6 Bar	85 PSI	6 Bar
Air Consumption	3.5 Cubic Ft/Cycle	79 liters/cycle	4.5 Cubic Ft/Cycle	102 liters/cycle	6 Cubic Ft/Cycle	68 liters/cycle
Electrical Press	115/1/60	240/1/50	115/1/60	240/1/50	115/1/60	240/1/50
Electrical Motors	208/230/3/60	380-415/3/50	208/230/3/60	380-415/3/50	208/230/3/60	380-415/3/50
Amperage Press	1 AMP @ 115 v		1 AMP @ 115 v		1 AMP @ 115 v	
Amperage Motors	15.4 AMP @ 230	4.6 kw	15.4 AMP @ 230	4.6 kw	15.4 AMP @ 230	4.6 kw
Net Weight	2500 lbs	1045 kg	3460 lbs	1455 kg	3,000 lbs	1360 kg

Buck Dimensions

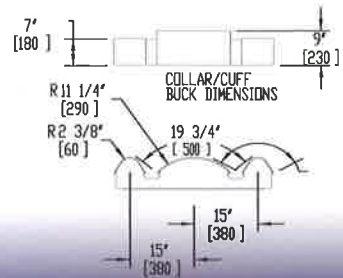
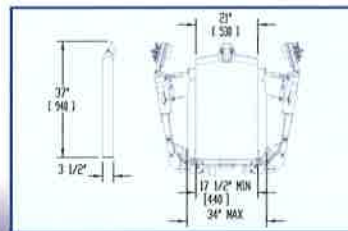

3501 Queen Palm Drive, Tampa FL 33619

813.623.3731 UnipressCorp.com

UNIPRESS